

ADRC Load Side Speed Controller Parameters Adjustment Based on a Neural Model Applied for a Nonlinear Two-Mass Drive System

Grzegorz Kaczmarczyk, Radoslaw Stanislawski, Marcin Kaminski, Lukasz Knypinski*, Danton Diego Ferreira**

Department of Electrical Machines, Drives and Measurements, Faculty of Electrical Engineering,
Wroclaw University of Science and Technology, 50-372 Wroclaw, Poland, email: marcin.kaminski@pwr.edu.pl

*Institute of Electrical Engineering and Electronics, Poznan University of Technology, 60-965 Poznan,
e-mail: lukasz.knypinski@put.poznan.pl

**Department of Automatics, Federal University of Lavras (UFLA), Caixa Postal 3037, Lavras 37203-202, MG, Brazil,
email: danton@ufla.br

Abstract – The paper is focused on improvements of conventional speed controller based on Active Disturbance Rejection Control (ADRC) applied for a two-mass electric drive system. The described ADRC control structure is based on load-side speed measurement. The paper compares conventional structure dynamics with overall system behavior in case plant parameters are changed. The proposed ADRC algorithm extension performs soft controller parameters adjustment to improve the dynamics and plant response. The presented approach accomplishes adaptation capabilities with the use of a Radial Basis Function Neural Network (RBFNN). The article compares the dynamic response of the plant controlled by a conventional ADRC algorithm and the designed neural adaptation extension through the conducted experimental tests.

I. INTRODUCTION

Modern electric drive systems are demanded to provide an excellent dynamic response of the plant combined with robustness to some phenomena which can occur unexpectedly. A control system can be considered robust if a change in plant parameters does not alter its response (completely or within the accepted range). However, in the case of complex mechanical constructions, change of inertia may cause non-negligible difference in plant behavior. Even though the response may be generally eligible, inconsistencies, oscillations, and ruggedness should still be mitigated. Finally, the mentioned inconveniences may affect the controlled object with failures or, in extreme conditions, sudden stability loss. Thus, it is crucial to mitigate speed lurches in sensitive plants. The proposed approach presents an online controller parameters adjustment algorithm accomplished by the RBFNN inclusion.

II. PLANT MODEL

The object analyzed in the article consists of two electric machines and a long, elastic shaft (connecting the motor with the load). Comprehensive analysis of the considered drive is presented in [1]. The mechanical part can be described as follows:

$$\begin{cases} J_1 \dot{\omega}_1 = T_e - (T_T + D(\omega_1 - \omega_2)) - T_{f1} \\ J_2 \dot{\omega}_2 = (T_T + D(\omega_1 - \omega_2)) - T_L - T_{f2} \end{cases}, \quad (1-2)$$

and:

$$\dot{T}_e = K_c(\omega_1 - \omega_2), \quad (3)$$

where: T_e is the electromagnetic torque, T_T is the torsional torque, T_L is the load torque, K_c is the stiffness coefficient, D is the damping coefficient, T_{f1} and T_{f2} are the friction torques.

III. CONTROL SYSTEM

One of the most common control method is known as Active Disturbance Rejection Control. It focuses on simplifying the plant model and implementing it in the form of a multi-integrator block. It minimizes the influence of external disturbances by storing an additional state variable and providing it to the control system. ADRC has been described in detail in [2]. Due to the fact, that ADRC approach is strongly dependent on the plant parameters, a risk of sudden, significant plant change is a huge concern. The algorithm proposed in the paper is based on the idea of load-side speed measurement only. That being said, referring to the plant model, the demanded motor speed change is achieved by calculating the third derivative of load machine speed which, after transformation, can be described with the following equation:

$$\ddot{\omega}_2 = \frac{D}{J_2} \dot{\omega}_2 - \frac{K_c}{J_2} \omega_2 + bu + A, \quad (4)$$

where: u is the control signal (electromagnetic torque), $b = \frac{K_c}{J_1 J_2}$, A is the additional disturbance. The described ADRC load side speed controller algorithm, applied for nonlinear two-mass system, has been thoroughly analyzed in [3].

The main assumption of the proposed approach is to extend the standard ADRC controller with an additional, floating coefficient, which can align the values of the tuned parameters in a limited range on the fly. Taking the current state of the plant into account, the controller follows the reference speed trajectory more accurately. To achieve this, an RBFNN was employed. Thus, the proposed ADRC speed controller equation can be presented with the following formula:

$$u_0 = (k_p(\omega_{ref} - \omega_2) - k_d z_2 - k_{dd} z_3) y_{RBF}, \quad (5)$$

where y_{RBF} is the RBFNN output, and can be described as follows:

$$y_{RBF} = \sum w_i \exp\left(-\frac{\|x - c_i\|^2}{2\sigma^2}\right), \quad (6)$$

where: c_i is the neuron center vector, x is the input, σ is the scaling factor, w_i is the weight coefficient. The final structure of proposed algorithm is shown in Figure 1.

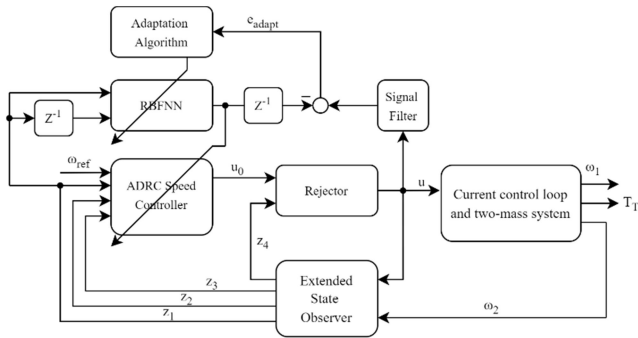

Fig. 1. The proposed ADRC structure with neural parameters adjustment.

IV. EXPERIMENT

The conducted tests were carried out using laboratory electric drive system with an elastic coupling [1]. Numerical calculations were executed with the use of *dSpace 1103* rapid-development programmable device. The overall scheme of the test bench is shown in Figure 2.

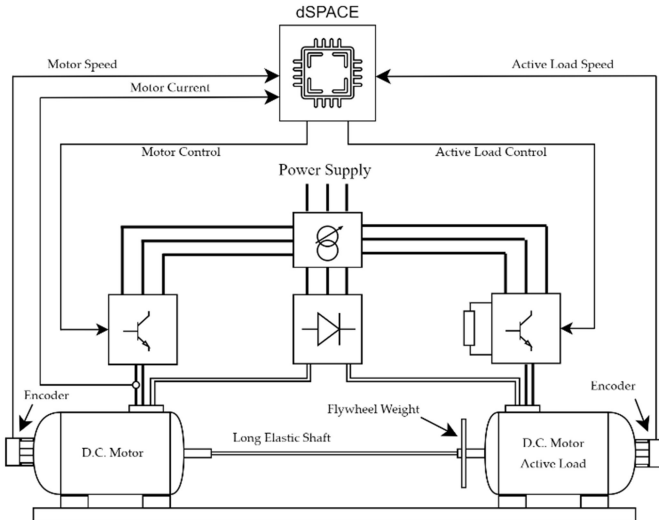

Fig. 2. Schematic diagram of experimental setup with a two-mass system.

At the beginning of the test series it was crucial to investigate if the conventional ADRC structure behavior satisfies the dynamic demanding in case load machine time constant is increased ($T_2 = 3T_{2n}$). The obtained results (including the zoom-in showing the steady state transition) are presented in Figure 3. The presented speed transients show a small inconvenience. The conventional ADRC structure does not make the actual speed value follow its reference trajectory precisely. The lurch, visible at $t = 21s$, may be harmful to the mechanical structure. In order to eliminate the visible nuisance, the second attempt assumed that all tuned controller parameters were increased with a specific, constant value. The obtained results were significantly better in the steady state transition. However, after additional load torque appeared, the system was unable to damp the occurred oscillations. Thus, the response of the proposed ADRC-RBFNN was compared to the conventional structure with increased controller parameters. The obtained results of both approaches are shown in Figure 4.

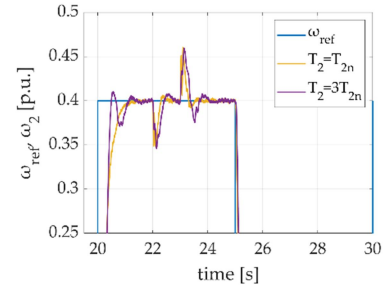
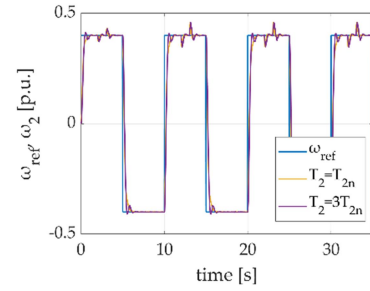

Fig. 3. Results (speed transients) of ADRC algorithm (applied for a drive with elastic connection) achieved under different values of the load machine time constant.

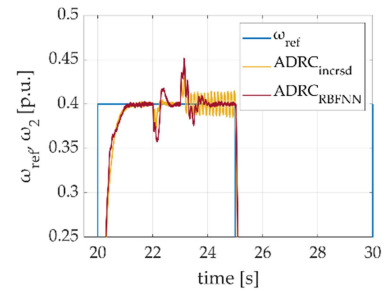

Fig. 4. The load speed transients for changed time constant value including modified control structures (zoom).

V. CONCLUSIONS

The presented approach demonstrates an extended ADRC load side speed controller. The introduced improvement adjusts tuned controller parameters in a small, limited range, basing on the system feedback. By doing so, robustness of the control algorithm has been increased. Applying an RBFNN allows compensating the occurred disturbances and lurches caused by significant time constant change of the plant. The conducted experiments have proven that the proposed algorithm deals with the described problem and constitutes a promising base for future works and upcoming research.

REFERENCES

- [1] Kaczmarczyk G., Stanislawski R., Szrek J., Kaminski M. Adaptive Sliding Mode Control Based on a Radial Neural Model Applied for an Electric Drive with an Elastic Shaft. *Energies* **2024**, *17*, 833. <https://doi.org/10.3390/en17040833>
- [2] Han J., "From PID to Active Disturbance Rejection Control," in *IEEE Transactions on Industrial Electronics*, vol. 56, no. 3, pp. 900-906, March 2009, doi: 10.1109/TIE.2008.2011621.
- [3] Wicher B., Brock S., "Active Disturbance Rejection Control Based Load Side Speed Controller for Two Mass System with Backlash," *2018 IEEE 18th International Power Electronics and Motion Control Conference (PEMC)*, Budapest, Hungary, 2018, pp. 645-650, doi: 10.1109/EPEPEMC.2018.8522001.